



# TG drives

## **TGN, TGH AND TGT SERVOMOTORS**

*Instruction manual.*

Information furnished by TG Drives, s.r.o. is believed to be accurate and reliable. However, no responsibility is assumed by TG Drives for its use. TG Drives reserves the right to change the design and operation of the equipment described herein and any associated motion products that may appear in this document. Information in this document pertaining to equipment not furnished by TG Drives should be confirmed by that equipment manufacturer. TG Drives assumes no responsibility for changes to information by other manufacturers or errors in that information or the description of that information. Information in this document is subject to change without notice.

# Instruction Manual

## For TGN, TGH and TGT servomotors

### 1. Introduction

#### 1.1 About

This manual describes the TGN, TGH and TGT series of synchronous servomotors (standard versions). The motors are operated in drive systems together with servoamplifiers. Please observe the system documentation, consisting of:

- Instruction manual for the servoamplifier
- Installation and setup instructions for any expansion card which is connected
- Online help of the amplifier's setup software
- Accessories manual
- Technical description of the TGN, TGH and TGT series of motors (this manual)
- **TEST REPORT** containing such information as electrical data, thermal protection type, feedback type and connectors connection of the servomotor, attached to every servomotor

#### 1.2 Personnel qualification

This manual addresses personnel with the following qualifications:

<b>Transport:</b>	only by personnel with knowledge of handling electrostatically sensitive components.
<b>Mech. Installation:</b>	only by mechanically qualified personnel.
<b>Electr. Installation:</b>	only by electrically qualified personnel.
<b>Setup:</b>	only by qualified personnel with extensive knowledge of electrical engineering and drive technology.

The qualified personnel must know and observe the following standards:

- IEC 60364 or DIN VDE 0100
- IEC 60664 or DIN VDE 0110
- national accident prevention regulations or BGV A3

**The operator must ensure that the safety instructions in this manual are followed. The operator must ensure that all personnel responsible for working with the motor have read and understood the product manual.**

## 2. Safety

### 2.1 Safety Notes

- Only properly qualified personnel are permitted to perform such tasks as transport, assembly, setup and maintenance. Properly qualified personnel are persons who are familiar with the transport, assembly, installation, setup and operation of motors, and who have the appropriate qualifications for their jobs. The qualified personnel must know and observe the following standards and regulations:
  - IEC 60364 or DIN VDE 0100
  - IEC 60664 or DIN VDE 0110
  - national regulations for safety and accident prevention or BGV A3
- Read the available documentation before assembly and setup. Incorrect handling of the motors can result in injury and damage to persons and machinery. Keep strictly to the technical data and the information on the connection requirements (nameplate and documentation).
- The manufacturer of the machine must generate a hazard analysis for the machine, and take appropriate measures to ensure that unforeseen movements cannot cause injury or damage to any person or property.
- It is vital that you ensure that the motor housing is safely earthed to the PE (protective earth) busbar in the switch cabinet. Electrical safety is impossible without a low-resistance earth connection.
- Do not unplug any connectors during operation. This creates the danger of death, severe injury, or extensive material damage.
- Power connections may be live even when the motor is not rotating. Never disconnect the power connections of the motor while the equipment is energised. This can cause flashovers with resulting injuries to persons and damage to the contacts.
- After disconnecting the servo amplifier from the supply voltage, wait at least five minutes before touching any components which are normally live (e.g. contacts, screw connections) or opening any connections.
- The surfaces of the motors can be very hot in operation, according to their protection category. The surface temperature can reach 100°C. Measure the temperature, and wait until the motor has cooled down below 40°C before touching it.
- Remove any fitted key (if present) from the shaft before letting the motor run independently, to avoid the dangerous results of the key being thrown out by centrifugal forces.

### 2.2 Product purpose

- The TGT and TGH series of synchronous servomotors is designed especially for drives for industrial robots, machine tools, textile and packing machinery and similar with high requirements for dynamics.
- The user is **only** permitted to operate the motors under the ambient conditions which are defined in this documentation.
- The TGT and TGH series of motors is **exclusively** intended to be driven by digital servo amplifiers under position and / or speed and / or torque control.
- The motors are installed as components in electrical apparatus or machines and can only be commissioned and put into operation as integral components of such apparatus or machines.
- The thermal contact which is integrated in the motor windings must be observed and evaluated.
- The conformity of the servo-system to the standards mentioned in the manufacturers declaration on page 8 is only guaranteed when the components (servo amplifier, motor, leads etc.) that are used have been supplied by us.

### 2.3 Not permitted use

- The use of the motors in the following environments is prohibited:
  - potentially explosive areas
  - environments with corrosive and/or electrically conductive acids, alkaline solutions, oils, vapours, dusts
  - directly on supply networks
- Commissioning the motor is prohibited if the machine in which it was installed
  - does not meet the requirements of the EC Machinery Directive
  - does not comply with the EMC Directive
  - does not comply with the Low Voltage Directive

## 2.4 **Transport**

- Climate category 2K3 to EN 50178
- Transport temperature -25...+70°C, max. 20K/hr change
- Transport humidity rel. humidity 5% - 95% , no condensation
- Only by qualified personnel in the manufacturer's original recyclable packaging
- Avoid shocks, especially to the shaft end
- If the packaging is damaged, check the motor for visible damage. Inform the carrier and, if appropriate, the manufacturer.

## 2.5 **Packaging**

- Motors are packed into a carton except the TGT8 series, they are packed in carton and pallet.

### 2.5.1 **Storage**

- Climate category 1K4 to EN 50178
- Storage temperature - 25...+55°C, max. variation 20K/hr.
- Humidity rel. humidity 5%...95%, no condensation
- Store only in the manufacturer's original recyclable packaging
- Storage time unlimited

## 2.6 **Maintenance**

- Maintenance and cleaning only by qualified personnel
- The ball bearings have a grease packing which is adequate for 20,000 hours of operation under normal conditions. The bearings should be replaced after 20,000 hours of operation under rated conditions (by manufacturer).
- Check the motor for bearing noise every 2500 operating hours, respectively each year. If any noises are heard, then the operation of the motor must stop, the bearings must be replaced (by manufacturer).
- Opening the motor invalidates the warranty.
- If the housing is dirty, clean housing with Isopropanol or similar, **do not immerse or spray**

## 3. Description of the motors

### 3.1 Design

- Synchronous servomotors in the TGN, TGH and TGT series are brushless AC motors for demanding servo applications. When combined with our digital servo amplifiers they are especially suited for positioning tasks in industrial robots, machine tools, transfer lines etc. With high requirements for dynamics and stability.
- The servomotors have permanent magnets in the rotor. The rare earth neodymium -iron-boron magnetic material is an important factor in making it possible to drive these motors in a highly dynamic fashion. A three-phase winding which is driven by the servo amplifier is integrated into the stator. The motor does not have any brushes since commutation is performed electronically by the servo amplifier.
- The temperature of the winding is monitored by temperature sensors in the stator windings and is signalled.
- A **resolver** is built into the motors as standard feedback element. The servo amplifiers evaluate the resolver position and supply sinusoidal currents to the motors.
- The motors can be delivered with or without a built-in holding brake. Retrofitting of the brake is not possible.
- The motors are enamelled in matt black (RAL 9005). This finish is not resistant against solvents (e.g. trichlorethylene, nitro-thinners, or similar).

### 3.2 Technical data

- **Climate category** 3K3 to EN 50178.
- **Ambient temperature** 5...+40°C for site altitude up to 1000m amsl (**at rated values**) It is vital to consult our applications department for ambient temperatures above 40°C and encapsulated mounting of the motors.
- **Permissible humidity** 95% rel. humidity, no condensation (**at rated values**).
- **Power derating** 1%/K in range 40°C...50°C up to 1000m amsl (**currents and torques**) for site altitude above 1000m amsl and 40°C:
  - 6% up to 2000m amsl
  - 17% up to 3000m amsl
  - 30% up to 4000m amsl
  - 55% up to 5000m amsl
- No derating for site altitudes above 1000m amsl with temperature reduction of 10K / 1000m.
- **Determination of nominal dates** Adapter flange with constantly 65°C.
- **Ball-bearing life** 20.000 operating hours.

### 3.3 Basic features

#### 3.3.1 Mounting Style

- The basic style for the TGN, TGH and TGT synchronous motors is style IM B5 according to EN 60034-7.

#### 3.3.2 Shaft

- Power transmission is made through the cylindrical shaft end (fit k6), with a locking thread (except TGT1, TGT2, TGH0 and TGH2) **with a fitted-keyway**. The shaft is balanced with a short (half) key.
- Bearing life is calculated with 20.000 operating hours.
- **Radial force** - If the motors drive via pinions or toothed belts, then high radial forces will occur. The permissible values at the end of the shaft may be read from the table below. The maximum values at rated speed you will find at the technical data. Power take-off from the middle of the free end of the shaft allows a 10% increase in Fr.
- **Axial force** - When assembling pinions or wheels to the axis and use of e.g. angular gearheads axial forces arise. The maximum values you will find at the table below.
- **Table of the maximum permissible axial and radial forces of the standard servomotors.**

- The conditions:
  - n = 3000 rpm
  - lifetime 20.000 operating hours
  - the point of radial force is the center of the shaft end

TYPE	TGT1	TGT2/H2/N2	TGT3/H3/N3	TGT4/H4/N4	TGT5/H5/N5	TGT6/N6	TGT7/N7	TGT8
F <sub>rmax</sub> (N)	91	225	370	638	665	639	1218	1702
F <sub>a</sub> max (N)	17	43	70	121	126	121	231	323

### 3.3.3 Flange

- Flange dimensions to IEC standard, fit j6, accuracy according to DIN 42955.
- Tolerance class: R

### 3.3.4 Ingress Protection

- Standard version IP64.
- Standard shaft bushing IP54.
- Shaft bushing with shaft-sealing ring IP65.

### 3.3.5 Thermal sensor

- The standard version of each motor is fitted with a thermal sensor (electrically isolated).  
The types of the thermal protection:
  - T0 = thermocontact
  - T1 = PTC 111-K13
  - T3 = KTY 83-110
  - T4 = KTY 84-130
- The thermostat does **not** provide any protection against short, heavy overloading. Provided that our preassembled resolver cable is used, the thermal sensor contact is integrated into the monitoring system of the digital servoamplifier.
- The flange temperature must not exceed 65°C in rated operation.**

### 3.3.6 Insulation class

- The motors come up to insulation material class F according to IEC 85.

### 3.3.7 Vibration

- The motors are made to vibration class A according to EN 60034-14. For a speed range of 600-3600 rpm and a shaft centre between 56-132mm, this means that the actual value of the permitted vibration severity is 1.6mm/s.

Velocity [rpm]	max. rel. Vibration Displacement [ $\mu\text{m}$ ]	max. Run-out [ $\mu\text{m}$ ]
$\leq 1800$	90	23
$> 1800$	65	16

### 3.3.8 Connection

- See the **Test Report** attached to every servomotor.

### 3.3.9 Feedback

- **Standard** Resolver two-pole hollow-shaft  
**Option** Resolver six-pole hollow-shaft (for TGT series only)
- **Option** EnDat Encoder, Single-Turn: TGN, TGH2, TGT2: **ECN 1113**, TGN3-7, TGH2-5, TGT3-8: **ECN 1313**  
**Option** EnDat Encoder, Multi-Turn: TGN2, TGH2, TGT2: **EQN 1125**, TGN3-7, TGH2-5, TGT3-8: **EQN 1325**
- **Option** Hiperface Encoder, Single-Turn: TGN2, TGH2, TGT2: **SKS 36**, TGN3-7, TGH2-5, TGT3-8: **SRS 50**  
**Option** Hiperface Encoder, Multi-Turn: TGN2, TGH2, TGT2: **SKM 36**, TGN3-7, TGH2-5, TGT3-8: **SRM 50**

The motor length changes when an encoder is mounted. Retrofitting is not possible.

### 3.3.10 Holding brake

- The motors are optionally available with a holding brake.
- A permanent magnet brake (24V DC) is integrated into the motors. When this brake is de-energized it blocks the rotor. **The holding brakes are designed as standstill brakes** and are not suited for repeated operational braking. If the brake is released then the rotor can be moved without a remanent torque, the operation is free from backlash! The motor length increases when a holding brake is mounted.
- The holding brake can be controlled directly by servo amplifiers (no personal safety!), the winding is suppressed in the servo amplifier — additional circuitry is not required.
- If the holding brake is not controlled directly by the servo amplifier, an additional wiring (e.g. varistor) is required. Consult our applications department beforehand.
- A personal safe operation of the holding brake requires an additional contact (normally opened) in the braking circuit and an anti-surge-device (e.g. varistor) for the brake.

### 3.3.11 Number of motor poles

- The motors TGT, TGH0 and TGN2/TGH2 series have 6 poles, the motors TGN3-7 and TGH3-5 series have 10 poles.

## 3.4 Options

- **Holding brake**
  - Built-in holding brake.
  - Motor length increases by the holding brake.
- **Radial shaft-sealing rings**
  - A radial shaft-sealing ring can be supplied at extra charge to seal against oil mist and oil spray. This increases the protection rating of the shaft bushing to IP65. The sealing ring is not suitable for dry running. When a holding brake is built in, the motor length increases by a sealing ring for approximately 10mm.
- **EnDat or Hiperface**
  - A high resolution EnDat-encoder or Hiperface-encoder is mounted instead of the resolver.
  - The motor length increases by the encoder.

All options can **not** be retrofitted.

## 3.5 Design of servomotor size

The three-phase servomotors are designed to operate with servo amplifiers. Together, both units form a closed speed or torque control loop. The most important selection criteria are:

- Standstill torque  $M_0$  [Nm]
- Rated speed  $n_n$  [min<sup>-1</sup>]
- Moment of inertia of motor and load  $J$  [kgcm<sup>2</sup>]
- Effective torque (calculated)  $M_{rms}$  [Nm]

When calculating the motors and servo amplifiers which are required, take account of the static load and the dynamic load (acceleration/braking). Collected formulae and examples of the calculations are available from our applications department.

## 4. Mechanical mounting

### 4.1 Notes

Only qualified staff with knowledge of mechanical engineering are permitted to assemble the motor.

- Protect the motor from unacceptable stresses. Take care, especially during transport and handling, that components are not bent and that insulation clearances are not altered.
- The site must be free of conductive and aggressive material. For V3-mounting (shaft end upwards), make sure that no liquids can enter the bearings. If an encapsulated assembly is required, please consult our applications department beforehand.
- Ensure an unhindered ventilation of the motors and observe the permissible ambient and flange temperatures. For ambient temperatures above 40°C please consult our applications department beforehand. Ensure that there is adequate heat transfer in the surroundings and the motor flange, so that the maximum permissible flange temperature of 65°C is not exceeded in S1 operation.
- Servomotors are precision equipment. The flange and shaft are especially vulnerable during storage and assembly — so avoid brute force. Precision requires delicacy. It is important to use the locking thread which is provided to tighten up couplings, gear wheels or pulley wheels and warm up the drive components, where possible. Blows or the use of force will lead to damage to the bearings and the shaft.

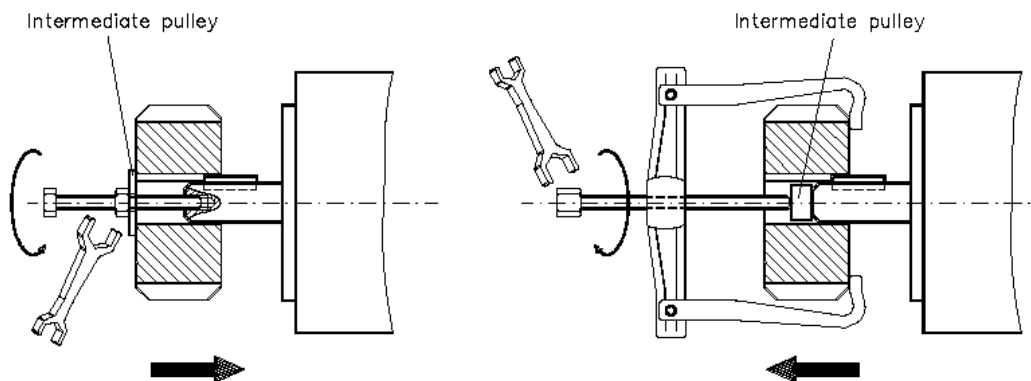

- Wherever possible, use only backlash-free, frictionally-locking collets or couplings. Ensure correct alignment of the couplings. A displacement will cause unacceptable vibration and the destruction of the bearings and the coupling.
- For toothed belts, it is vital to observe the permissible radial forces. An excessive radial load on the shaft will significantly shorten the life of the motor.
- Avoid axial loads on the motor shaft, as far as possible. Axial loading significantly shortens the life of the motor.
- In all cases, do not create a mechanically constrained motor shaft mounting by using a rigid coupling with additional external bearings (e.g. in a gearbox).
- Take note of the no. of motor poles and the no. of resolver poles, and ensure that the correct setting is made in the servo amplifier which is used. An incorrect setting can lead to the destruction of the motor, especially with small motors.
- Check the compliance to the permitted radial and axial forces  $F_R$  and  $F_A$ . When you use a toothed belt drive, the **minimal** permitted diameter of the pinion e.g. follows from the equation:

$$d_{min} \geq \frac{M_0}{F_R} \times 2$$



## 5. Electrical Installation

### 5.1 *Safety*

- Only staff qualified and trained in electrical engineering are allowed to wire up the motor.
- Always make sure that the motors are de-energized during assembly and wiring, i.e. No voltage may be switched on for any piece of equipment which is to be connected. Ensure that the switch cabinet remains turned off (barrier, warning signs etc.).
- The individual voltages will only be turned on again during setup.
- Never undo the electrical connections to the motor while it is energised. A dangerous voltage, resulting from residual charge, can be still present on the capacitors up to 5 minutes after switch-off of the mains supply.
- Measure the DC-link voltage and wait until it has fallen below 40V.
- Even when the motor is not rotating, control and power leads may be live.
- The ground symbol, which you will find in the wiring diagrams, indicates that you must provide an electrical connection, with as large a surface area as possible, between the unit indicated and the mounting plate in the switch cabinet. This connection is to suppress HF interference and must not be confused with the PE (protective earth) symbol (protective measure to EN 60204).
- To wire up the motor, use the wiring diagrams in the Installation and Setup Instructions of the servo amplifier which is used.