

Universal Rod Style Actuators

K Series™ Linear Actuators

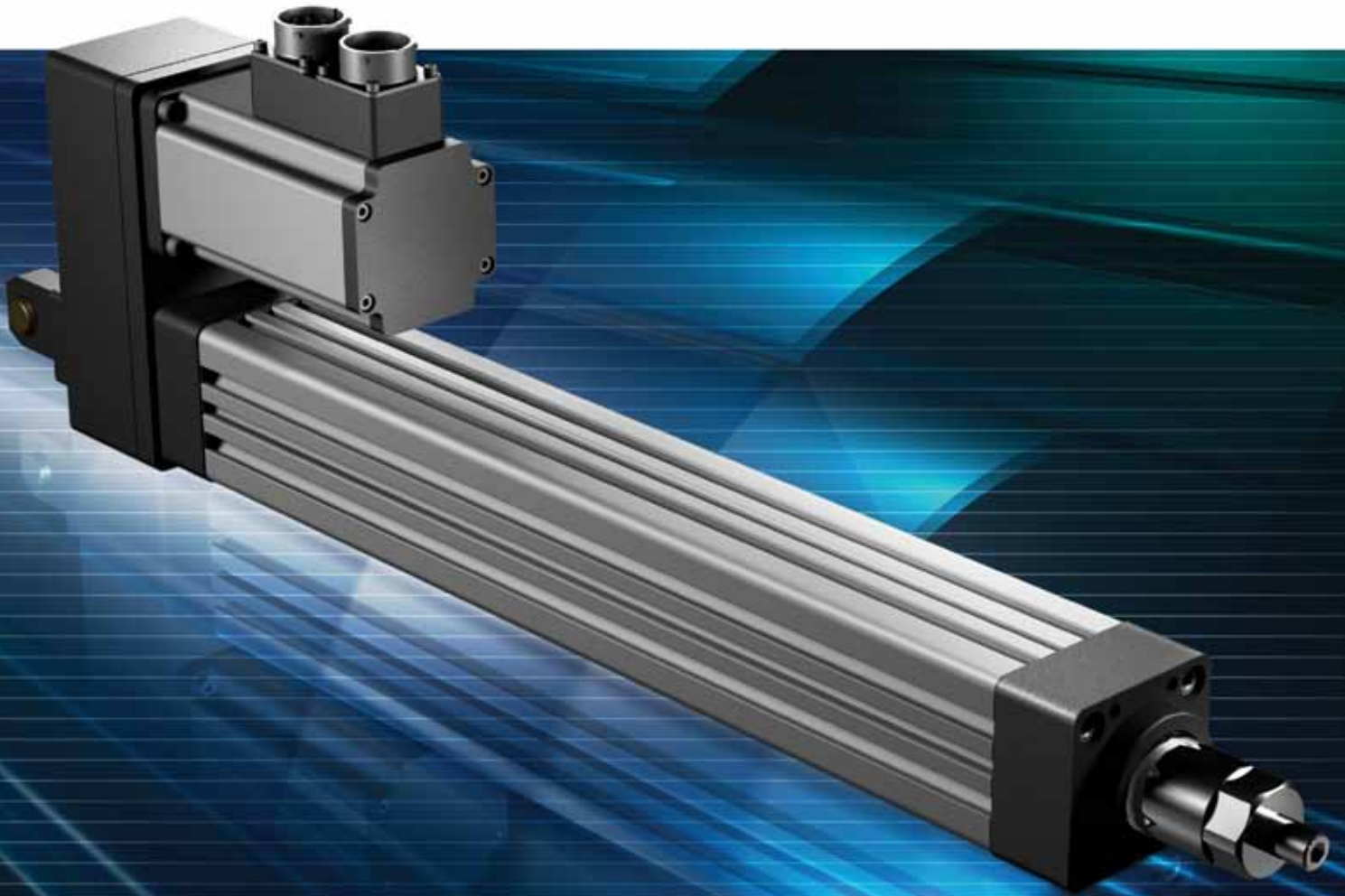

EXLAR

K Series™ Linear Actuators

The K Series actuators offer Exlar's roller screw technology in varying performance levels and allow the use of lower cost motor technology.

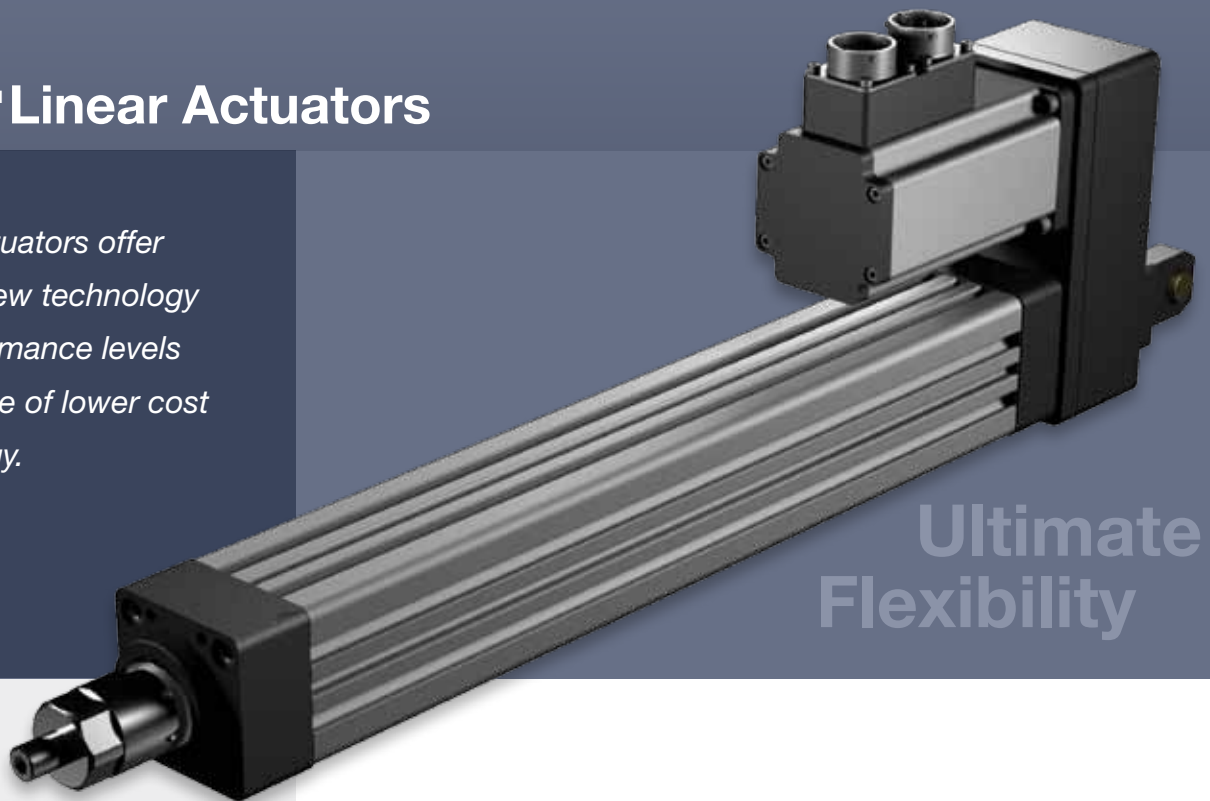

A Universal Design Providing Ultimate Flexibility

The K Series actuators from Exlar provide a truly universal solution for rod style actuator applications. The series is available with the option of multiple grades of planetary roller screws and with an option for an ACME screw. These multiple grades of screw type allow you to select the configuration best suited to your application. The K Series provides an ideal replacement for pneumatic cylinders, with dimensions and form factor consistent with ISO Metric pneumatic cylinder specifications. The availability of high performance planetary roller screw drive allows the K Series to also replace hydraulic cylinders and provide a solution that offers superior life and performance to ball screw actuators.

Multiple Models to Fit Your Needs

Four product performance levels are available, so you can choose which option best suits your application and budgetary requirements.

KT Series incorporates Exlar's highest performance precision planetary roller screw. The KT option is perfectly suited for high load and high cycle rate applications where maximum life is required.

KX Series provides a high performance planetary roller screw for performance far superior to competing actuator technologies. The KX is an ideal choice for demanding applications in Industrial Automation, Mobile Equipment, Process Control and others.

KM Series gives you the benefits of planetary roller screw technology over ball screws at a very economical cost.

KA Series actuators are constructed with an ACME screw for low duty cycle applications with 2.54 mm and 5.08 mm leads. The KA Series can provide non-back driving solutions with a 2.54 mm lead. The KA Series is an excellent choice for applications that position and hold a load, or need effective low duty cycle electro-mechanical motion.

K Series Features

- Proven Exlar roller screw technology
- Flexible mounting options
- Adapts to various types of motors
- Optional gear drives for high force output from lower motor torques

Inline servo motor with rear clevis. Exlar also manufactures high performance servo motors. The SLM Series servo motors can be offered with a rear clevis to be used with the inline motor mount of the K Series.

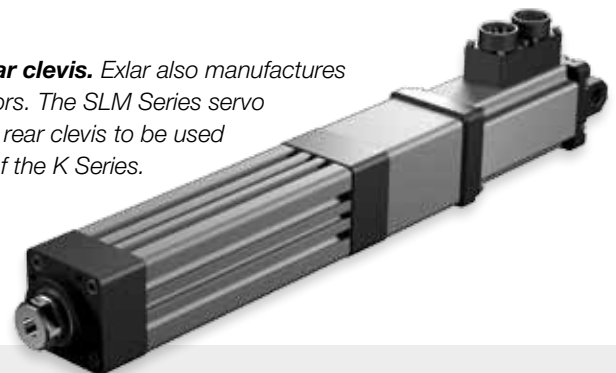

The Exlar Advantage

Mounting of Any Type Motor

The K Series allows for complete flexibility in the type and style of motor to be mounted to the actuator. You can select mounting provisions for brushless servo motors, stepper motors, DC brushed motors or other types of motors for driving your K Series actuator.

Universal Mounting Options

The K Series offers a wide variety of fixed and adjustable mounting accessories, consistent with ISO Metric pneumatic cylinder standards. Exlar also offers the user the rare option to have an inline mounted Exlar servo motor with a rear clevis or rear eye mount for pivoting applications. The mounting options include:

- Front Flange
- Rear Flange
- Rear Clevis
- Rear Eye
- Adjustable Side Trunnion
- End Angles
- Foot Mount



Standard Actuator Construction

The standard K Series actuator design provides an anodized aluminum housing for excellent corrosion resistance use in many environments. The standard main rod is nickel plated steel with a 304 SS rod end insert providing excellent wear characteristics.

Input Transmissions

The K Series™ can be provided with parallel motor mounts with belt transmissions. Ratios of 1:1 to 2:1 are offered standard. Other options include a direct drive inline mount or a base unit without motor mounting provisions.

Sealed Body Design

The standard body design of the K Series provides an IP65 sealed housing and motor mount, when allowable by the design of motor to be used. This allows the actuators to be used in applications where spray is present, without needing to select special options.

Special Materials and Coatings

For applications not served by the standard product design, Exlar offers a variety of special materials and coating options. The aluminum actuator body components can be provided with alternative coatings, such as Type III hard coat anodizing, electroless nickel plating or epoxy coating. The actuators main rod can be provided in stainless steel construction.

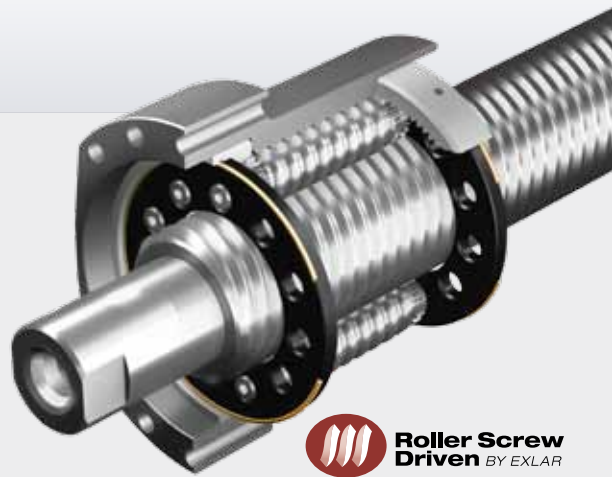

Roller Screw Basics

Exlar's patented, inverted roller screw is a mechanism for converting rotary torque into linear motion, similar to acme screws or ball screws. But, unlike those devices, roller screws can carry heavy loads for thousands of hours in the most arduous conditions. This makes roller screws the ideal choice for demanding, continuous-duty linear motion applications. The difference is in the roller screw's design for transmitting forces. Multiple threaded helical rollers are assembled in a planetary arrangement around a threaded shaft, as seen below, which converts a motor's rotary motion into linear movement of the shaft or nut.

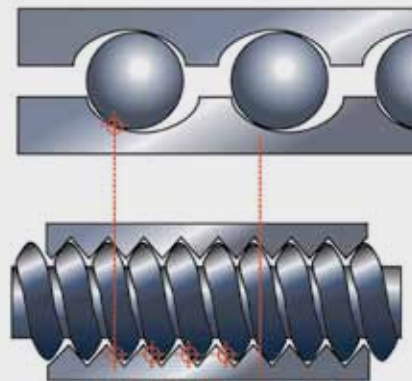

Compare a similar size ball screw to Exlar's planetary roller screw design and see many more contact points on the roller screw. This results in higher load-carrying capacity and improved stiffness.

K Series™ Specifications

K Series Performance Specifications

Product Model	Frame Size mm (in)	Screw Lead mm (in)	Max Allowable Force ⁴ N (lbf)	Input Torque @ Max Force ⁴ Nm (lbf-in)	Speed at Max Rated Input RPM mm/sec (in/sec)	Max Rated Input RPM	Life at Max Force ¹ mm x 10 ⁶ (in x 10 ⁶)	Dynamic Load Rating N (lbf)
Roller Screw Models								
KT60-xx05	60 (2.36)	5 (0.1968)	8005 (1800)	7.97 (70.5)	416 (16.4)	5000	30.8 (1.21)	14682 (3300)
KT60-xx10	60 (2.36)	10 (0.3937)	4000 (900)	7.97 (70.5)	833 (32.8)	5000	348 (13.17)	12900 (2900)
KX60-xx05	60 (2.36)	5 (0.1968)	6005 (1350)	5.94 (52.6)	416 (16.4)	5000	26.7 (1.05)	10500 (2360)
KX60-xx10	60 (2.36)	10 (0.3937)	3003 (675)	5.94 (52.6)	833 (32.8)	5000	297.2 (11.7)	9300 (2091)
KM60-xx05	60 (2.36)	5 (0.1968)	6005 (1350)	5.94 (52.6)	416 (16.4)	5000	10.43 (0.41)	7673 (1725)
KM60-xx10	60 (2.36)	10 (0.3937)	3003 (675)	5.94 (52.6)	833 (32.8)	5000	127 (5.0)	7006 (1575)
Acme Screw Model²								
KA60-01	60 (2.36)	2.54 (0.1)	3693 (830)	5.94 (52.6)	27 (1.1)	650 ³	NA	NA
KA60-02	60 (2.36)	5.08 (0.2)	3101 (697)	5.94 (52.6)	54 (2.2)	650 ³	NA	NA

- The L_{10} expected life of a roller screw linear actuator is expressed as the linear travel distance that 90% of properly maintained roller screws manufactured are expected to meet or exceed. For higher than 90% reliability, the result should be multiplied by the following factors: 95% x 0.62; 96% x 0.53; 97% x 0.44; 98% x 0.33; 99% x 0.21. This is not a guarantee and these values should be used for estimation purposes only. The formula that defines this value is: Travel Life in millions of mm, where: C = dynamic load rating (N); F = cubic mean applied load (N); S = Roller screw's lead. $L_{10} = (C/F)^3 \times S =$
- Acme screw life expectancy: As a result of the high friction inherent to acme screws, life expectancy is unpredictable. Load, duty cycle, speed, temp, and lubrication all affect the amount of heat generated and thread wear by the acme nut which ultimately determines the life of the mechanism. Acme screws typically have lower life expectancies than roller screws and should only be used in low duty cycle applications.
- $P \times V$ for ACME screws should be kept below 0.1 $P = \text{Force}/\text{Max Force}$; $V = \text{Speed}/\text{Max Speed}$
- Input torque should be limited such that Max force is not exceeded. For a parallel belt ratio, the input torque ratings must be divided by the belt ratio for allowable motor torque. The output force ratings remain the same.

K Series Mechanical Specifications

		KT60	KX60	KM60	KA60
Nominal Backlash	mm (in)	0.1 (0.004)	0.2 (0.008)	0.2 (0.008)	0.356 (0.014)
Lead Accuracy	$\mu\text{m}/1000 \text{ mm}$ (in/ft)	G5:23 (0.00096)	G9: 200 (0.0024)	G9: 200 (0.0024)	NA
Maximum Radial Load		See Chart			
Environmental Rating: Standard		IP65	IP65	IP65	IP65
Maximum Operating Temperature	$^{\circ}\text{C}$ ($^{\circ}\text{F}$)	80 $^{\circ}\text{C}$ (175 $^{\circ}\text{F}$)			
Weights kg (lbs)					
Base Unit - Zero Stroke		1.7 (3.7)			
Adder Per mm of Stroke		0.008 (0.017)			
Adder for Inline (excluding motor)		0.42 (0.93)			
Adder for Parallel Drive (excluding motor)		0.73 (1.6)			
Adder for Front/Rear Flange		0.42 (0.93)			
Adder for Rear Clevis		0.44 (0.98)			
Adder for Rear Eye		0.30 (0.67)			
Adder for Front/Rear Angle Mounts		0.24 (0.54)			
Adder for 2 Trunnions		0.37 (0.82)			
Adder for Foot Mounts		0.45 (1)			

K Series Allowable Radial Load v. Extended Length

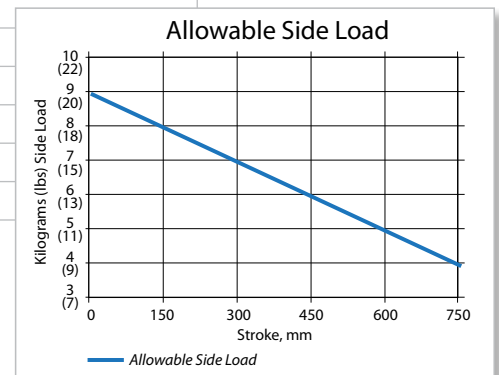

K Series Actuator Inertias

K60 Actuator	5 mm Lead	Add per 25 mm Lead
	kg-m ² (lbf-in-sec ²)	kg-m ² (lbf-in-sec ²)
Base Unit - Input Drive Shaft Only	1.480 x 10 ⁻⁵ (1.31 x 10 ⁻⁴)	2.034 x 10 ⁻⁵ (1.80 x 10 ⁻⁴)
Inline Unit - w/Motor Coupling	2.702 x 10 ⁻⁵ (2.39 x 10 ⁻⁴)	2.034 x 10 ⁻⁵ (1.80 x 10 ⁻⁴)
1:1 Reduction Belt Drive (66 mm)	4.339 x 10 ⁻⁵ (3.84 x 10 ⁻⁴)	2.034 x 10 ⁻⁵ (1.80 x 10 ⁻⁴)
1:1 Reduction Belt Drive (86 mm)	7.378 x 10 ⁻⁵ (6.53 x 10 ⁻⁴)	2.034 x 10 ⁻⁵ (1.80 x 10 ⁻⁴)
1:1 Reduction Belt Drive (96 mm)	8.564 x 10 ⁻⁵ (7.58 x 10 ⁻⁴)	2.034 x 10 ⁻⁵ (1.80 x 10 ⁻⁴)
1.5:1 Reduction Belt Drive (86 mm)	5.014 x 10 ⁻⁵ (4.44 x 10 ⁻⁴)	9.057 x 10 ⁻⁵ (8.02 x 10 ⁻⁵)
2:1 Reduction Belt Drive (96 mm)	7.095 x 10 ⁻⁵ (6.28 x 10 ⁻⁴)	5.084 x 10 ⁻⁶ (4.50 x 10 ⁻⁵)
	10 mm Lead	Add per 25 mm Lead
	kg-m ² (lbf-in-sec ²)	kg-m ² (lbf-in-sec ²)
Base Unit - Input Drive Shaft Only	1.616 x 10 ⁻⁵ (1.43 x 10 ⁻⁴)	7.864 x 10 ⁻⁵ (6.96 x 10 ⁻⁴)
Inline Unit - w/Motor Coupling	2.837 x 10 ⁻⁵ (2.51 x 10 ⁻⁴)	7.864 x 10 ⁻⁵ (6.96 x 10 ⁻⁴)
1:1 Reduction Belt Drive (66 mm)	4.474 x 10 ⁻⁵ (3.96 x 10 ⁻⁴)	7.864 x 10 ⁻⁵ (6.96 x 10 ⁻⁴)
1:1 Reduction Belt Drive (86 mm)	7.514 x 10 ⁻⁵ (6.65 x 10 ⁻⁴)	7.864 x 10 ⁻⁵ (6.96 x 10 ⁻⁴)
1:1 Reduction Belt Drive (96 mm)	8.704 x 10 ⁻⁵ (7.70 x 10 ⁻⁴)	7.864 x 10 ⁻⁵ (6.96 x 10 ⁻⁴)
1.5:1 Reduction Belt Drive (86 mm)	5.075 x 10 ⁻⁵ (4.49 x 10 ⁻⁴)	3.493 x 10 ⁻⁵ (3.09 x 10 ⁻⁴)
2:1 Reduction Belt Drive (96 mm)	1.966 x 10 ⁻⁵ (1.74 x 10 ⁻⁴)	1.966 x 10 ⁻⁵ (1.74 x 10 ⁻⁴)

*See drawings on page 6 for belt drive dimension reference

K Series™ Accessories

Model Number	K Series Mounting Attachments (including proper number of std T nuts and screws)
KSRF-60	Rear Flange Attachment
KSFF-60	Front Flange Attachment*
KSEA-60	End Angles (includes 2)
KSEP-60	End Angles Parallel (includes 2)
KSFM-60	Foot Mounts (includes 2)
KSST-60	Side Trunnions (includes 2)
KSRC-60	Rear Clevis (includes pins)
KSRE-60	Rear Eye
KSMT-60	Metric Side Trunnion
KSMC-60	Metric Rear Clevis (includes pins)
KSME-60	Metric Rear Eye
Rod End Attachments	
SRM-050	Front Spherical Rod Eye, fits "M" Rod only
REI-050	Front Rod Eye, fits "M" Rod only
RCI-050	Front Rod Clevis, fits "M" Rod only
Clevis Pins	
CP-050	Clevis Pin for Front and Rear Clevis and Rod Eyes
KSMP-60	Metric Clevis Pin for Rear Metric Clevis and Rod Eyes
Limit Switches	
43404	Normally Closed Limit Switch
43403	Normally Open Limit Switch

*Consult Exlar application engineering to discuss maximum stroke length allowable with your final configuration.

K Series Ordering Information

K_AA-BBBB-CC-DE-FFF-GGG - (XX..XX - #####)

Actuator Series

KT = Highest Capacity Roller Screw
 KX = High Capacity Roller Screw
 KM = Standard Capacity Roller Screw
 KA = Acme Screw

AA = Actuator Frame Size

60 = 60 mm (2.375 inch)

BBBB = Stroke Length (mm)

0020 - 0750 mm (30 inch nominal)¹

CC = Lead (linear motion per screw revolution)

05 = 5 mm (0.2 inch) roller screw only
 10 = 10 mm (0.4 inch) roller screw only
 01 = 2.54 mm (0.1 inch) acme screw only
 02 = 5.08 mm (0.2 inch) acme screw only

D = Mounting Options

N = None, Base Unit

E = Rod End Options

M = Male, US Std thread W = Male, US Std thread, SS
 A = Male Metric thread R = Male Metric thread, SS
 F = Female US Std thread V = Female US Std thread, SS
 B = Female Metric thread L = Female Metric thread, SS

FFF = Input Drive Provisions

NMT = Drive Shaft Only, No Motor Mount
 ISC = Inline, Includes Shaft Coupling
 P10 = Parallel, 1:1 Ratio
 P15 = Parallel, 1.5:1 Ratio

P20 = Parallel, 2:1 Ratio

P## = Custom Ratio, (ex. P13 = 1.3:1 ratio)

GGG = Motor Mount Provisions

A## = Alpha numeric motor call out - contact Exlar Applications Engineering Department. Motor not included.
 NMT = No motor mount - keyed shaft on base unit only
 N23 = Nema 23 standard dimension
 N34 = Nema 34 standard dimension
 M60 = Exlar 60 mm SLM, motor not included
 M90 = Exlar 90 mm SLM, motor not included
 G60 = Exlar 60 mm SLG, motor not included
 AB2,3 = Rockwell 2 & 3 inch (60 & 80 mm) motors
 BD2,3 = Baldor 2 & 3 inch (60 & 80 mm) motors
 EM2,3 = Emerson CT Metric 2 & 3 inch (60 & 80 mm) motors
 FA2,3 = Fanuc 2 & 3 inch (60 & 80 mm) motors
 IN2,3 = Bosch-Rexroth (Indramat) 2 & 3 inch (60 & 80 mm) motors
 KM2,3 = Danaher 2 & 3 inch (60 & 80 mm) motors
 MT2,3 = Mitsubishi 2 & 3 inch (60 & 80 mm) motors
 PC2,3 = Parker 2 & 3 inch (60 & 80 mm) motors
 SM2,3 = Siemens 2 & 3 inch (60 & 80 mm) motors
 YS2,3 = Yaskawa 2 & 3 inch (60 & 80 mm) motors

The above list is a small representation of the motor options available. Please contact Exlar for additional motor mounting provisions.

X..XX = Travel and Housing Options (Multiple Possible)

SE = Smooth extrusion (no mounting or switch grooves)
 EN = Electroless nickel plating of housing parts³
 HC = Hard coat anodized, acceptable for food grade³

WE = White epoxy coating²

PB = Protective bellows for extending rod

L1 = One External Limit Switch, channel mount magnetic sensing prox, N.O.

L2 = Two External Limit Switches, channel mount magnetic sensing prox, 2 N.C.

L3 = Three External Limit Switches, channel mount magnetic sensing prox, 1 N.C., 2 N.O.

L# = External Limit Switches, channel mount magnetic sensing prox

XH = Special housing option

XL = Special lubrication (food grade, Mobilgrease 28 or other, please specify)

XT = Special travel option

= 5 digit part number assigned to designate special model numbers.

Optional 5 digit assigned part number to designate unique model numbers

NOTES:

1. Minimum stroke length is 20 mm. For longer strokes than 750 mm contact Exlar.
2. Recommended only with SE option.
3. If special coatings are selected for use in applications where collection of contaminants is better if avoided, consider use of the SE option for smooth extrusion. This option eliminates the attachment-only mounting grooves, and end mounted accessories will be usable with the unit.

K60 Dimensions and Motor Mounting Options

K60 Base Unit

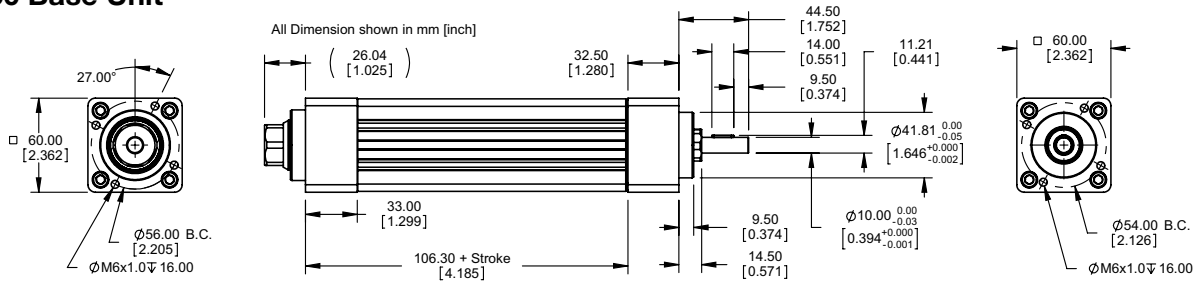

K60 Mounting Accesories (Ordered Separately)

K60 Trunnion Mount (KSST-60, KSMT-60)

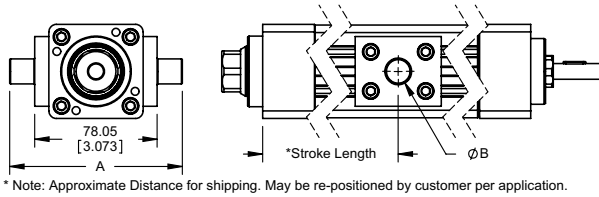

Version	Dim "A"	Dim "øB"
KSST-60	4.928"	1.000 +/- .001"
KSMT-60	106.88 mm	16.00 -.03 mm/- .07 mm

K60 Foot Mount (KSFM-60)

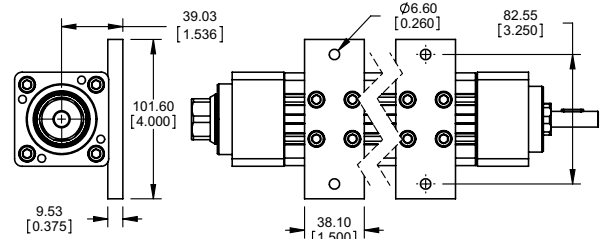

Mounting position shown for dimensions only. Feet may be positioned on any side, at any distance.

K60 Front Flange (KSFF-60)

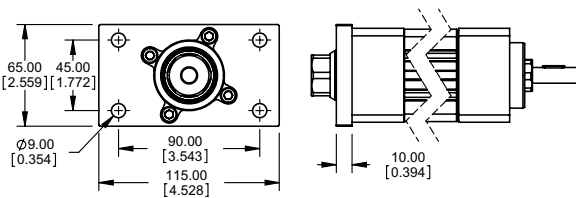

K60 End Angles (Inline-KSEA-60, Parallel-KSEP-60)

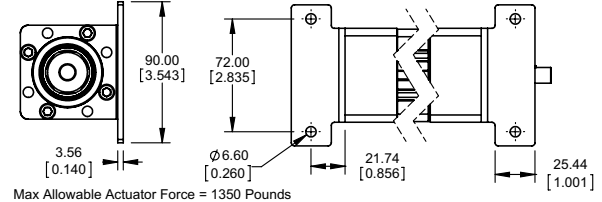

K60 Motor Mounting Options

K60 Inline Intergrated Coupling (ISC)

Non-Std Motor Mount	Inch	Metric
Diameter	1/4, 3/16, 3/8, 1/2, 5/8	10, 12, 14, 15, 16
Std Motor Mount	Diameter	Length
M60	14 mm	30 mm
G60	16 mm	36 mm
M90	19 mm	40 mm
N23	0.25 in	0.81 in
N34	0.5 in	1.19 in

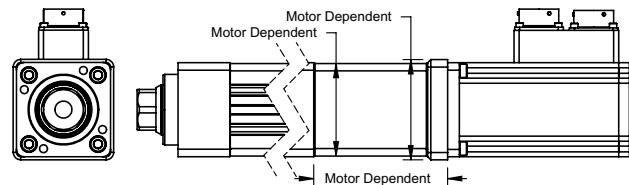

K60 Parallel Drive (PXX)

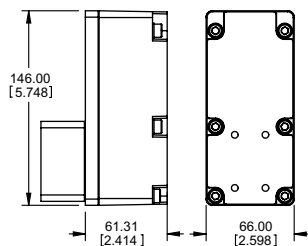

~60 mm Motor (NEMA 23)		
Ratio	Max Motor Shaft ø	Min/Max Motor Shaft Length
1:1	14 mm	30 mm/44 mm

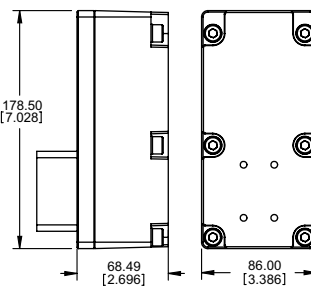

60-80 mm Motors		
Ratio	Max Motor Shaft ø	Min/Max Motor Shaft Length
1:1 - 1.5:1	14 mm	40 mm/56 mm

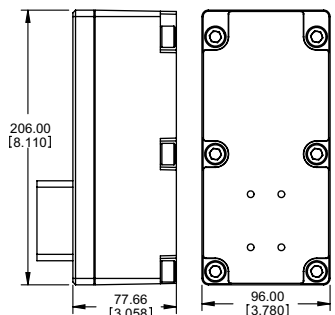

60-90 mm Motors (NEMA 34)		
Ratio	Max Motor Shaft ø	Min/Max Motor Shaft Length
1:1 - 2:1	19 mm	30 mm/60 mm

K60 Parallel Only Mounting Options (Ordered Separately)

Rear Clevis (KSRC-60, KSMC-60)

Rear Eye (KSRE-60, KSME-60)

K60 Rear Flange (KSRF-60)

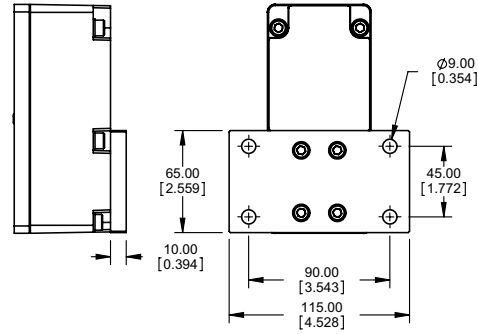
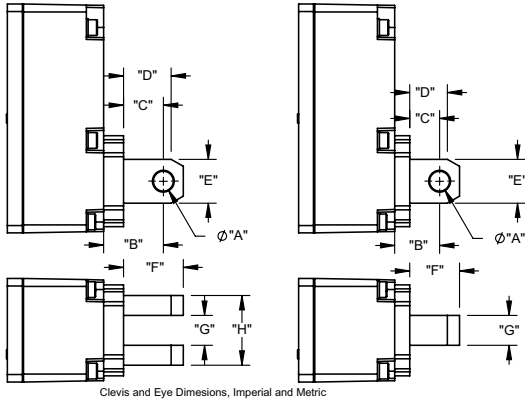

Option	Dim A	Dim B	Dim C	Dim D	Dim E	Dim F	Dim G	Dim H
Inch Clevis (KSRC-60)	.500" +.004/+ .002	1.500"	1.000"	1.700"	1.100"	1.500"	.750" +.020/- .000	1.750" +.000/- .029
Metric Clevis (KSMC-60)	12 mm +.04/- 0	25.00 mm	16.00 mm	21.00 mm	24.00 mm	28.00 mm	28.00 +.52/- .00 mm	52.00 +.00/- .74 mm
Inch Eye (KSRE-60)	.500" +.004/+ .002	1.125"	.750"	1.325"	1.100"	1.250"	.750" +.008/- .024	N/A
Metric Eye (KSME-60)	12 mm +.04/- 0	25.00 mm	16.00 mm	21.00 mm	24.00 mm	28.00 mm	28.00 +.20/- .60 mm	N/A

K60 Rod End Attachments

SRM 050	Spherical Rod Eye
A	2.125" (54.0 mm)
Ø B	.500" (12.7 mm)
C	1.156" (29.4 mm)
D	1.312" (33.3 mm)
E	6 Deg
F	.500" (12.7 mm)
G	.625" (15.9 mm)
H	.875" (22.2 mm)
J	.750" (19.1 mm)
K	1/2-20

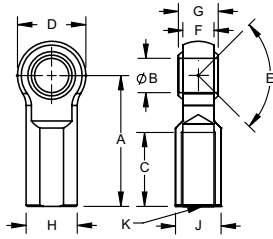

RCI 050	Rod Clevis
A	.750" (19.05 mm)
B	.750" (19.05 mm)
C	1.500" (38.1 mm)
D	.500" (12.7 mm)
E	.765" (19.43 mm)
Ø F	.500" (12.7 mm)
Ø G	1.000" (25.4 mm)
H	1.000" (25.4 mm)
Ø J	N/A
K	1/2-20

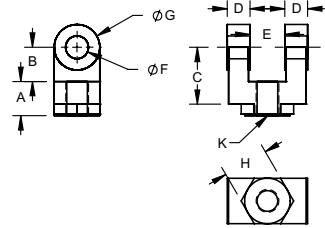

REI 050	Rod Eye
Ø A	.50" (12.7 mm)
B	.75" (19.05 mm)
C	1.50" (38.1 mm)
D	.75" (19.05 mm)
E	.375" (9.53 mm)
F	1/2-20

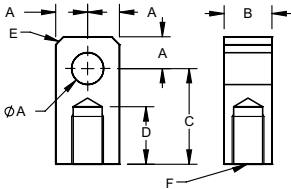

Clevis Pin	KSMP-60	CP 050
A	2.56" (65 mm)	2.28" (57.9 mm)
B	2.19" (55.50 mm)	1.94" (49.28 mm)
C	.19" (4.75 mm)	.17" (4.32 mm)
Ø D	.47" (12 mm)	.50" (12.7 mm)
Ø E	.12" (3 mm)	.095" (2.41 mm)

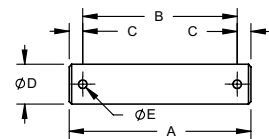

K60 Rod Ends

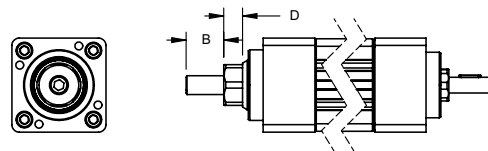
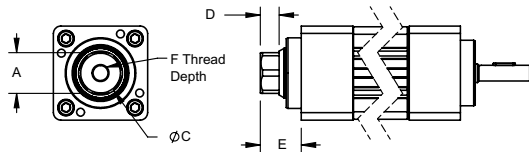

Rod End Option	Thread	A	B	C	D	E	F
M	U.S. Male 1/2-20 UNF-2A	1.02" (28.00 mm)	.875" (22.2 mm)	1.102" (28.00 mm)	0.427" (912.00 mm)	.992" (25.20 mm)	N/A
F	U.S. Female 1/2-20 UNF-2B	1.02" (28.00 mm)	N/A	1.102" (28.00 mm)	0.427" (912.0 mm)	.992" (25.20 mm)	.75" (19.0 mm)
A	Metric Male M12 x 1.25 6g	1.02" (28.00 mm)	.945" (24 mm)	1.102" (28.00 mm)	0.427" (912.0 mm)	.992" (25.20 mm)	N/A
B	Metric Female M12 x 1.25 6H	1.02" (28.00 mm)	N/A	1.102" (28.00 mm)	0.427" (912.0 mm)	.992" (25.20 mm)	.70" (17.80 mm)



Headquartered at our manufacturing and motion control research center in suburban Minneapolis, MN, Exlar serves a global customer base with an extensive standard product line and complete engineering support for custom applications.

Exlar provides sales and support world-wide. To find your local representative, visit our website at www.exlar.com or call our headquarters at 952-500-6200.

Request a free copy of our literature by calling **952-500-6200** or download the pdf at **www.exlar.com**. In addition to the 2011 Product Catalog, brochures are available on Exlar's component roller screws and Tritex or Tritex II Actuators with Embedded Electronics. Process control and defense industry brochures are also available.

Exlar Corporation
18400 West 77th Street
Chanhassen, MN 55317

TEL: 952.500.6200
Toll FREE: 855.620.6200
General FAX: 952.368.4877
Order Only FAX: 952.368.4359

www.exlar.com

EXLAR